

Skegness Raceway Lady Rookie Bangers 2024

If it doesn't say you can do it You cannot do it!!!!

Checks can be carried out at any time on any part of the car, and regardless of the situation with other cars, BOC decisions will be taken on the status of your car only. **Any driver may buy another drivers engine (inc ECU) and gearbox less inlet, carb and exhaust manifold for £500 this can only be done by the driver getting the correct form from race control and paying when the form is complete. Payment goes via the promotion. If the driver refused to sell it's a 12 month Full ORC ban.**

There will be an automatic minimum three month ban which will be issued for threatening behaviour, and a minimum 12 months which will be issued for physical violence offences, a second offence will have a harsher penalty. This applies to all driver's and team members in all formulae.

Rookie Bangers are intended to be a training ground for a new driver's although experienced drivers are very welcome to join in. Light contact and nudge and spin only is permitted drivers are allowed to spin cars towards the centre green, no deliberate fencing.

It is stressed that this is a limited contact formula and drivers who engage in deliberate wrecking tactics, deliberate following in, dangerous driving, hitting parked cars, will not be permitted to continue in Rookie Bangers. If you want to race in a full contact formula then the other banger formulas run by Skegness Stadium are for you.

Team Racing – Polite reminder that team racing is NOT allowed. Two cars onto one at the same time, may result in the steward penalising drivers, with the possibility of them being referred to the BOC

1 Cars

Any hatchback, saloon or estate car (no 7 seaters) under 1600cc or under 1800cc single cam 8 valve engines may be used. The following cars may not be used for Rookie Bangers: Mondeo, Cortina, Capri, Crunardos, Cougar, BMW Minis, Vectra, Insigna or Tigras.

Regarding Ford Focus no engine swap. Car must remain on injection system. No forwards facing manifolds and carburettors ie Ford Focus and puma etc.

Also No cars eligible for Micro bangers may be used in Rookie Bangers.

Corsa D may be used in Rookie Bangers

2. The Racing

All drivers must be 16 year old or over.

Only LIGHT contact as necessary to pass another vehicle.

Drivers who have never raced before will be able to begin Rookie Bangers in the white grade.

Following infringements are not allowed and may result in a ban,

Corner cutting to spin another car.

Deliberate following in of another vehicle into the fence.

Dangerous driving.

Crashing into parked / or empty cars.

Spinning cars into the wall.

3. Preparation

Remove all exterior mouldings, headlamps, door handles, bumper over riders and exterior mirrors.

Steering columns & steering wheels are free and we recommend they should be padded with high density foam.

Remove all glass, interior trim, headlinings, floor coverings, passenger seats,

Remove all obsolete wiring.

Remove old fuel tanks.

Remove spare wheel carriers and tow bar.

Headlamps and rear lamp apertures should not be filled in.

Dashboards must be removed.

All window mechanisms must be removed from the driver's door.

4. Bodywork

The front wings may be trimmed below the front bumper level but no folding. One 13mm nut and bolt may be used to secure bottom of wing.

All doors must be either bolted or chained. At least one bolt through pillars is recommended. Driver door may be welded.

A 1.5mm piece of tin may be fitted on the inner wing to cover any big hole where the water bottle has been removed, either bolted or welded.

NO ADDITIONAL WELDING IS ALLOWED.

5. Door Plate Compulsory and other plates

A steel plate 10" to 15" deep $\frac{3}{8}$ " – $\frac{3}{4}$ " thick must be bolted over the driver's door. This must be fitted with a minimum of 3" and a maximum of 6" past the A & B pillars securely bolted with a minimum of four bolts, with a minimum size 4 x 16mm of at least two of the bolts 24 mm head. With suitable washers. There must be at least 1 bolt on each side of the A & B pillars. Only flat plate is allowed. No channel, angle or corrugated steel is allowed. You must not cut slots – holes only.

A steel plate may be fitted to the driver's floor pan. It must be no thicker than 6mm, and must be bolted and welded in. This may be modified to rise to the maximum height of the sill of the door side only.

A flat steel plate MUST be fitted to the roof with the following instructions picking up cage bolts and must come forward to the front of A pillar. Minimum size plate 3mm max 6mm thick and must have 2 bolts each side minimum and 3 across front. Minimum bolt size 12mm, 19mm spanner size nut. Maximum size bolt 16mm, 24mm spanner.

6. Engines

Air filter may be removed.

An oil filter guard is mandatory. May be as per the diagram below. cam guard can now be used but can only be bolted to the engine.

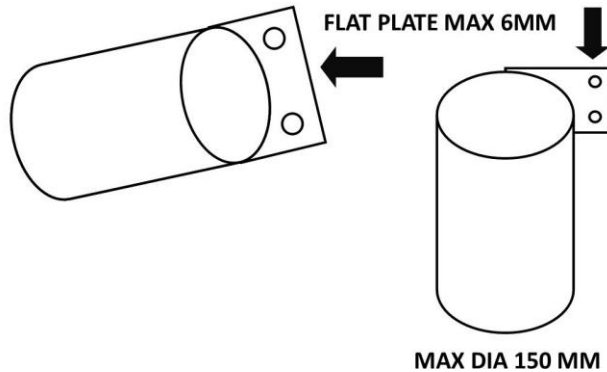

Everything must remain as manufactured to the car and standard

No distributor guards.

One Solid mounting allowed, but in original position, but no bigger than the original mounting.

Carburettors are free on all engines up to a maximum of 2L twin choke carb. The single cam 1800 Vauhall may be used

Multipoint injection can be used with a return back to the tank or a t-piece fitted in the fuel line between the fuel tank and the fuel pump. The electrical isolation switch (cut off switch) must be fitted in the N/S/R window area of the B post for easy access of the safety marshal.

Fuel injections may be modified to carburettor using a manufactured or adapted inlet manifold and must run with one standard downdraft Weber type carburettor to a maximum size or equivalent

Fuel injections may be modified to carburettor using a manufactured or adapted inlet manifold and must run with one standard downdraft Weber type carburettor to a maximum size or equivalent eg Pierburg, Solex, Weber – NO MULTIPLE CARB SETUPS

Injection system may be removed, a carburetor fitted, max size is twin choke webber, fitted to the Ford Pinto 2Litre , choke size 32 36 & choke must work progressively.

A clutch guard is permitted on front of the engine/gearbox if fitted forward facing of the engine, with a maximum size as follows:- 6" x 4" and a maximum thickness of 6mm.

This must be secured to the engine/gearbox only.

7. Gearbox / Axle

Gearbox must be standard to the car along with clutch and fly wheel

Axle and ration must be as manufactured to the car

No locked diffs or limited slips.

8. Paintwork

Drivers must NOT paint their cars in team colours or similar to that of other cars.

Bright colours are recommended and a good overall appearance is required.

Names and numbers on both sides of car.

9. Mirrors

May be used inside of the car only.

10. Bumpers Front

All cars to have original front bumper removed and bumper added as per the diagram. And that must not stick out past the front of the bonnet. Front bumper brackets must not extend more than 150mm up the chassis legs, chassis legs must also remain open.

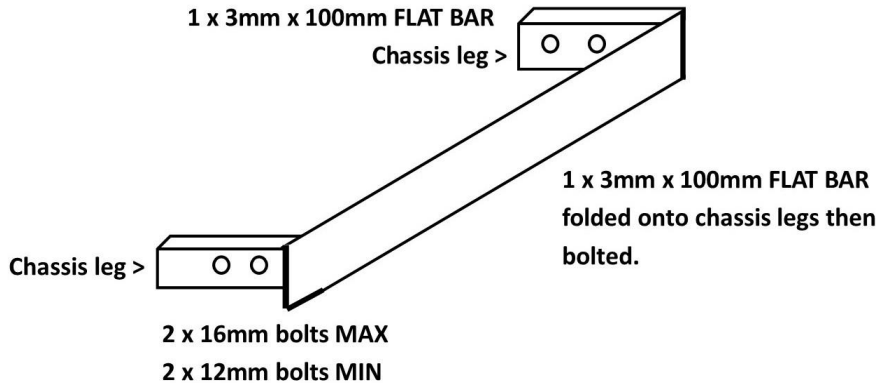

11. Bonnets

Bonnets may be removable but must be bolted down using four bolts, max 16mm, 2 bolts in either side of the bonnet with a minimum of 18" between the front and rear. Corner plates may also be fitted. There may be occasions when certain cars can have no inner wings for the bolts to go through --- then a piece of box section may be welded to the chassis (40mm x 40mm 3mm thick steel) for the bolt to pass through max length 50mm.

Bonnets must be removed when going to scrutineering.

The maximum exposed height above the surface for all bolts to be 1½" maximum. No added metal to the bonnets is allowed. Bonnets must also remind in the original position to the car.

Shuttering bolts may only be used for bonnet bolts providing they only protrude past the top of the wing nut by 1½" and are taped up to ensure they do not come loose. These are not recommended.

No fixing of webs to bonnet.

12. Brakes & Suspension

Must remain as manufactured and be working on all four wheels.

Camber on Rookie bangers is not permitted. New cars must be standard only. Race damage will be up to 1 inch only. Any exceeding 1 inch will be made to rectify before can race. No fitting of smaller bolts to obtain camber, if you are caught doing this don't cry.

Springs must be standard to the car (as it left the factory) raced and not cut to lower the car, no modifications to any other part including shockers, no competition shockers, no camber to be ADDED to any wheel.

No strut braces allowed

13. Wheels & Tyres

Standard road tyre as fitted to car up to 6.5 J steel or aluminium, (correct studs must be fitted).

Maximum size tyre 195, lowest profile 50 series minimum. Equal size tyres must be fitted across axle.

Remove hubcaps. Remove all balance weights.

No competition tyres. No Yokohamas, no cut tyres. No mud and snow. No Maxsports, Nobbles, Colways, Michelin, Dunlop, Continental, Pirelli, Goodyear, Fulda, Kieber, Vredestein, Sempit, BF Goodrich, Linglong, Bridgestone, Federal, Barum, Hankook, Marshall, Kumho. Or any road test tyres at NOT allowed.

55 series profile tyres are allowed to be used.

14. Battery

Must be securely fixed and must be bolted to roll cage, not in the foot well. They cannot be left under the bonnet. They must be covered with rot proof material.

A battery cut off switch **MUST** be mounted on the roll cage on the nearside of the battery and **MUST** work and be clearly marked.

Alternators may remain fitted but all wiring removed from the back of the alternator.

Ignition switches must be used, **NO** bare wires.

24 volts to starter motor maybe used.

15. Radiators

1. Radiators are free & may be moved to any position in the engine bay.

2. Electric cooling fans may be wired through a separate switch.

3. A bulkhead water tank maybe fitted, must not go further forward on the passenger side than the centre line of the turret, driver side must not go forward at all, meaning **NO** U-shaped tanks. These must not be bolted to the turret and bulkhead bolts must not be connected to door plates or floor plates.

16. Fin Plates

You must fit a fin plate to the roof of your car, minimum size 18" x 12" and a maximum size of 20"x15".

Your number must be either white on a black background or black on a white background, no other colours allowed, no other writing allowed, minimum size 9" high x 1½" wide.

You may also paint your number on each side of the car in contrasting colours.

17. Driver's Seat

A seat with a head restraint must be fitted. The seat must be securely mounted at shoulder height to the cross bar or to the rollover bar and bolted securely to floor.

NO racing seats allowed.

18. Roll Bars

Must be one complete frame, **NO** scaffold poles / clamps.

The roll cage must be fitted upright not leaning back or forward.

Minimum size of steel is 50mm x 50mm Box, minimum of 3ml thick.

Make sure you have plenty of padding on roll cage particularly near your headline, including the B pillar.

6 fixings of 17ml (4 bottom and two top) with adequate washer.

Two uprights with cross bar welded. Uprights must have 4" plates welded to the base to stop pushing them through the floor.

At least one, maximum two, cross bars must be used to reach to reach to doors or pillars and must have 4" plates welded to both ends to stop them punching through the doors.

At least one of the cross bars must be at roof level.

The use of an adjustable roll frame is permitted to enable the same frame to be used in cars with different widths. If an adjustable frame is used, the moving parts must lie outside the two uprights and be securely bolted into place with a minimum of 0.5" bolts.

18a Fuel Systems

Only roadside fuel is allowed.

Fuel shut off tap within easy reach of the driver and must be working. **Good Condition fuel pipe is compulsory, metal or correct line for unleaded fuel no garden hose or gas pipe**

Metal Fuel tank with outlet from the top of the tank with a secure screw on metal cap with a one way valve fitted to breather pipe. It is mandatory that the Petrol tanks are bolted to the roll cage .

Overflow must be top outlet and pass through car floor.

Multipoint injection can be used with a return back to the tank in the fuel line between the fuel cut off tap and the fuel pump. The electrical isolation switch (cut off switch) must be fitted in the N/S/R window area of the B post for easy access of the safety marshal.

With carburettor fuelled cars, **a manual shut-off tap must be fitted within reach of the driver when strapped in the car**, but with fuel injected cars, the fuel flow must be controlled by the pump cut off switch. Immersed fuel pumps are permitted.

20. Exhaust Systems Standard exhaust middle box must be used, rear box maybe removed. No cherry bombs or cherry bomb types are allowed. You must run a silencer. A Fordson Major exhaust may be used.

21. Helmets

Helmets must be of a minimum standard as directed by British Oval Racing Safety Executive (B.O.R.S.E). These are A/FR, FIA8860-2004, Snell SA2005, Snell SA2010, SFI Foundation

31.1A, SFI Foundation 31.2A. The E2205 European standard helmet may be used in Fibreglass, Carbon or Tri-Composite form only i.e. NO POLYCARBONATE helmets are allowed. It is important that the helmet fits the driver correctly. Shatterproof goggles/visors must be worn although tinted visors are not advisable. Your helmet must display the current ORCi (ORC15) sticker

22. Safety equipment

Neck braces are recommended.

Fire proof balaclavas are MANDATORY and must be marked appropriately.

Fireproof gloves are MANDATORY and must be marked appropriately.

23. Seat Belts

A full shoulder type safety harness as approved by ORCi with lap strap must be fitted and bolted to the floor.

A minimum of a four point buckle fixing must be used with a minimum of 4 floor fixings.

A. secure part of the floor or cage (including the seat bar) are recommended anchor points.

Single point buckle fixing harness are not allowed.

A suitable head restraint must be fitted to the roll cage or seat.

More safety equipment is detailed at the front of this publication

24. Foot Plate

A steel plate fitted to the driver's floor-pan is highly recommended. It must be no thicker than 6mm, and must be bolted and/or welded in. This may be modified to rise to the maximum height of the sill of the door side only.